

**SPECIAL PROVISION  
CONCRETE PAVEMENT REPLACEMENT AND REPAIR**

This Special Provision will apply when indicated on the plans or proposals. Section references herein are to the Department's 2008 Standard Specifications for Road and Bridge Construction.

**1.0 DESCRIPTION.** Remove and replace concrete pavement, in both full and partial depths and both full and partial panels. Comply with the applicable Standard Drawings and the Standard Specifications except as specifically superseded herein.

**2.0 MATERIALS AND EQUIPMENT.**

**2.1 JPC Pavement.** Conform to Section 601.02. When the Engineer approves, the Department will allow JPCP 24/48/72 conforming to Section 502.

**2.2 Latex Materials.** Conform to Section 606.

**2.3 Tie Bars.** Conform to Section 811. Use epoxy coated tie bars in longitudinal and transverse joints.

**2.4 Silicone Rubber Sealant.** Conform to Subsection 807.03.01 or 807.03.05.

**2.5 Epoxy Resin Systems.** Conform to Section 826.

**2.6 Dense Graded Aggregate (DGA).** Conform to Section 805.

**2.7 Drills.** Drills used to make holes shall be held in a rigid frame to assure proper vertical and horizontal alignment with misalignment not to exceed 3/8 inch in the vertical or oblique plane.

**2.8 Hammers.** Only use chisel point hammers weighing less than 40 pounds to remove deteriorated concrete.

**3.0 CONSTRUCTION.**

**3.1 Full Depth Removal of Existing Pavement.** Remove to the extent the Contract specifies or as the Engineer directs. The minimum length of patches measured along centerline is 5 feet on each side of an existing joint; or Section A-A = 10 feet, Section B-B = 10 feet, Section C-C = 60 feet, Section E-E = 35 feet, and Section F-F = 35 or 60 feet.

The length of Section DD = 8 feet minimum, and no closer than 8 feet to any transverse joint. If it is necessary to remove existing pavement closer than 8 feet to a transverse joint, remove the pavement 5 feet beyond that joint and the reconstructed joint.

Details of configurations of pavement and joints for various situations are depicted in the drawings herein (reference numbers on sections A-A through F-F are the same as on Standard Drawing No. RPS-010).

When small areas of removal and replacement are performed at bridge ends, maintain or reconstruct existing expansion joints at their existing location. When the Engineer determines extensive full width removal and replacement is required,

construct new expansion joints at the locations shown on Standard Drawing No. RPN-010.

In the removal operation, make a full depth saw cut longitudinally along the centerline joint and shoulder joint and transversely along the area marked for removal. The Engineer may direct or approve additional longitudinal cuts within the removal area for ease of removal of the damaged slab and to prevent damage to adjacent pavement to remain in place. Keep overcutting beyond the limits of the removal area to a minimum. Prevent saw slurry from entering existing joints and cracks. Clean all saw slurry and other contaminants from overcutting area. Repair overcut area with a low viscosity epoxy compound.

During removal operations do not damage the base, shoulder, or sides of pavement not to be removed. If any damage does occur, repair as the Engineer directs.

### **3.2 Full Depth Pavement Replacement.**

**3.2.1 Preparation of Base.** Compact the existing aggregate base to the Engineer's satisfaction. The Engineer will accept compaction by either visual inspection or by nuclear gauge. When it is necessary to stabilize the existing base or replace unsuitable materials, excluding bridge ends, use DGA. At bridge ends, treat existing base and subgrade as the Contract specifies. During compaction, wet the base as the Engineer directs. Compact areas not accessible to compaction equipment by hand tamping.

**3.2.2 Underdrains.** At locations of full depth pavement replacement, construct pavement edge drains according to Section 704 after the pavement has been replaced. If underdrains are placed omitting areas to be patched, construct additional lateral drains as necessary to provide outlets for the installed underdrain until performing the pavement replacement and completing the underdrain system.

**3.2.3 Pavement Replacement.** Using load transfer assemblies for dowel joints drill into the existing slab according to the details shown herein and on the Standard Drawings.

Use epoxy coated smooth dowels of the size specified on the standard drawings for contraction and expansion joints.

Drill holes for dowel bars into the face of the existing slab, at a diameter 1/8 inch larger than the dowel size and to a depth equal to 1/2 the length of the bars. Operate the equipment to prevent damage to the pavement being drilled. Obtain the Engineer's approval of the drilling procedure. Install load transfer assemblies according to the Standard Drawings and Standard Specifications.

Use 3/4 inch deformed tie bars, 18 inches long on 30-inch centers in the longitudinal joint. Use one-inch deformed tie bars 18 inches long on 12-inch centers in transverse construction joints.

Install dowels and tie bars in the existing slab using Type IV epoxy. Install the dowels and tie bars according to Section 511.

Mix, place, finish, and cure concrete according to Section 501 except the Department will allow truck mixing, 2-bag mixers, and hand finishing.

When required, use a form on the side of the slab at longitudinal joints. When the adjacent traffic lane is not closed to traffic or the drop-off is not protected, temporarily fill the space between the form and the adjacent pavement with DGA. After placing the slab, remove the DGA and form. Fill

the hole with concrete and thoroughly consolidate by rodding, spading, and sufficient vibration to form a dense homogeneous mass. With the Engineer's approval, the Department will allow the application of bond breaker. Use a form on the side of the slab adjacent to shoulders. Excavate and backfill as shown on Section F'-F'.

When resurfacing is required, a float finish is satisfactory. Otherwise, broom finish or, when the adjacent surface has a grooved finish, texture the surface according to Subsection 501.03.13 H).

Finish the surface, including joints, to meet a surface tolerance of 1/8 inch in 10 feet.

Keep all pavement surfaces adjacent to this operation reasonably clean of excess grout and other materials at all times.

Maintain all original longitudinal joints. Place transverse joints according to the details shown herein and on the Standard Drawings.

**3.3 Partial Depth Patching.** Saw the hole to be patched with a vertical face, to a 2-inch minimum depth and to the configuration the Contract specifies or the Engineer directs. After sawing, keep exposure to traffic to a minimum until patching.

If the area to be patched is adjacent to an existing joint or is deeper than 1/2 the slab depth, construct full depth patches according to Section 3.2 herein.

Keep overcutting beyond the limits of the removed area to a minimum. Prevent saw slurry from entering existing joints and cracks. Clean all saw slurry and other contaminants from overcutting. Repair the overcut area with a low viscosity epoxy compound.

Use either Portland cement concrete or latex concrete.

**3.3.1 Portland Cement Patch.** Use a mixture conforming to Section 501 except use a minimum cement factor of 7 bags per cubic yard, No. 9M coarse aggregate, and at least 20 ounces per cubic yard of either Type A or Type D water reducing admixture. Submit a mix design for the Engineer's approval. Clean the patch area by sandblasting. Vigorously scrub a grout bond coat into the sandblasted area. Use a grout consisting of a slurry made of water mixed with equal parts of Portland cement and mortar sand.

Place the patch before the grout shows any sign of drying. Cure according to Subsection 501.03.15.

**3.3.2 Latex Concrete Patch.** Prepare the patch area and apply a latex grout bond coat. Furnish, place, and cure the latex concrete according to Subsections 606.02, 606.03.02, 606.03.08, 606.03.09, and 606.03.17. Ensure the curing materials required by Subsection 606.03.17 A) 4) remain in place for the specified time. Remove and replace all areas of the patches that display cracks or that are not bonded to the underlying pavement.

**3.4 Joint Sealing.** Seal all new or partially new joints with silicone rubber sealant according to Subsection 501.03.18 D).

Details for removing JPC pavement at transverse joints

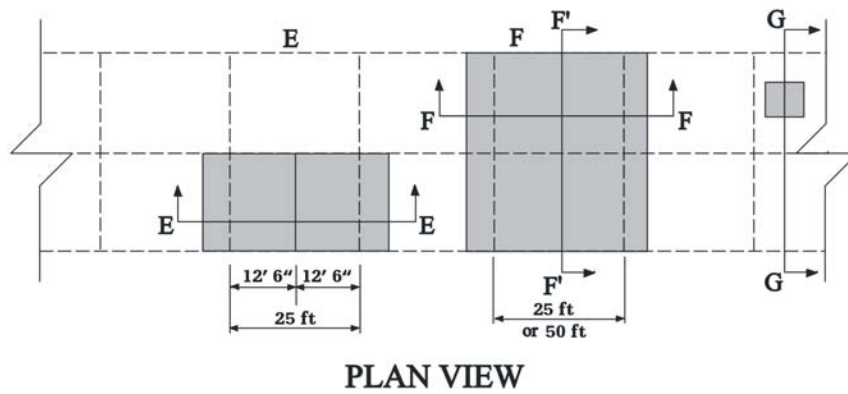
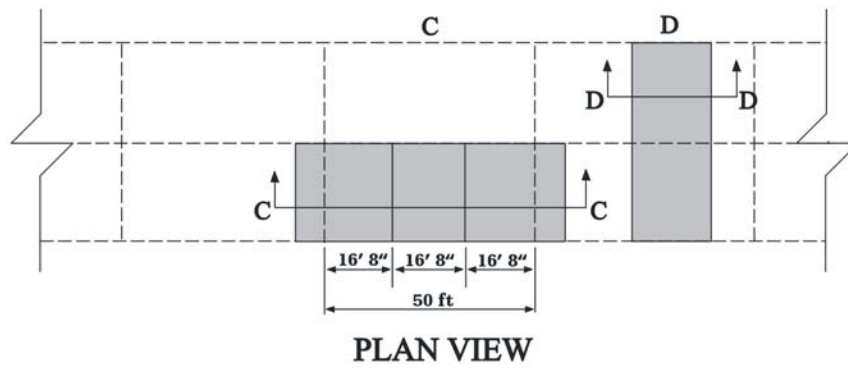
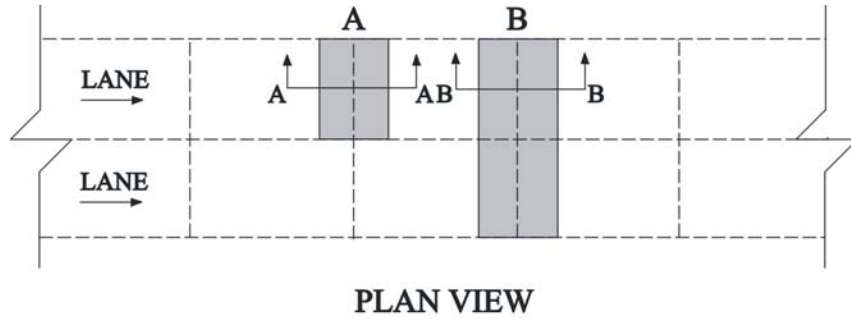

 JPC PAVEMENT  
 TO BE REMOVED

### Section A-A

- 1) Saw at locations 4 and along longitudinal joint full depth without damage to existing concrete. Saw relief joints as the Engineer directs or approves. Remove the existing JPC pavement and dowel assembly to the length and at the locations noted elsewhere in the Contract.
- 2) Install 24 one-inch tie bars 18 inches long on 12-inch centers beginning 6 inches from the outside shoulders at locations 4 and install new 3/4 inch tie bars 18 inches long on 30-inch centers in the longitudinal joint. Install all tie bars in existing pavement using epoxy Type IV.
- 3) Install new load transfer assembly and align with the remaining joint.
- 4) Replace with non-reinforced JPC pavement and install a contraction joint at location 3 and construction joints at locations 4. Seal all joints with silicone rubber seals.

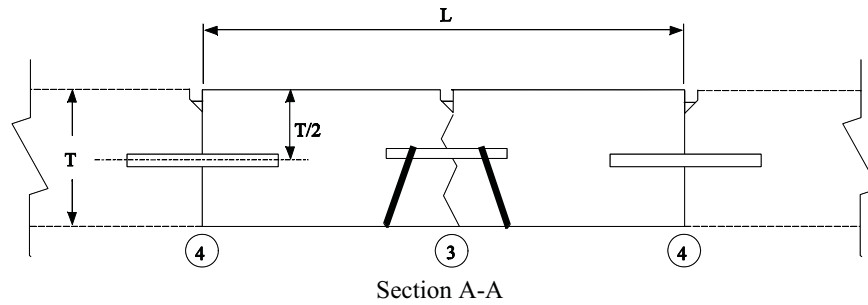

### Section B-B

- 1) Saw at locations 5 full depth without damage to existing concrete. Saw relief joints as the Engineer directs or approves. Remove the existing JPC pavement to the length and at the locations noted elsewhere in the Contract.  $L = 8$  feet minimum.
- 2) Install 48 smooth-load transfer dowels, 18 inches long (see Standard Drawing No. RPS-020 for size) at locations 5. Install dowels in the existing concrete using epoxy Type IV. Install dowels on 12-inch centers beginning 6 inches from the outside shoulder. Install one-inch expansion joint material according to Standard Drawing No. RPS-020.
- 3) If  $L$  is greater than 20 feet, install new load transfer assembly(s) and construct contraction joints such that the distance between joints in the replaced section is no less than 10 feet nor more than 20 feet.
- 4) Construct longitudinal joint(s) according to the Standard Drawing except use 3/4-inch tie bars 18 inches long on 30-inch centers.
- 5) Replace with non-reinforced JPC pavement and seal all joints with silicone seals.

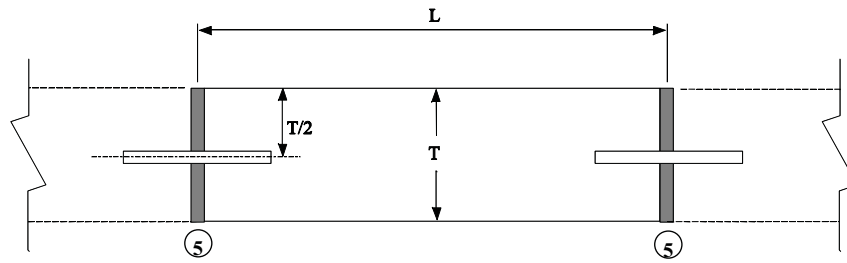

Section B-B

### Section C-C

- 1) Saw at locations 4 and along longitudinal joint full depth without damage to existing concrete. Saw relief joints as the Engineer directs or approves. Remove the existing pavement and dowel assemblies to the length and at the locations noted elsewhere in the Contract.
- 2) Install 24 one-inch tie bars 18 inches long on 12-inch centers beginning 6 inches from the outside shoulder at locations 4, and install new 3/4-inch tie bars 18 inches long on 30-inch centers in the longitudinal joint. Install all the bars in the existing pavement using Type IV epoxy.
- 3) Install new load transfer assemblies at locations 3, aligning with the existing joint where applicable.
- 4) Replace with non-reinforced JPC pavement and install contraction joints at location 3 and construction joints at locations 4. Seal all joints with silicone rubber seals.

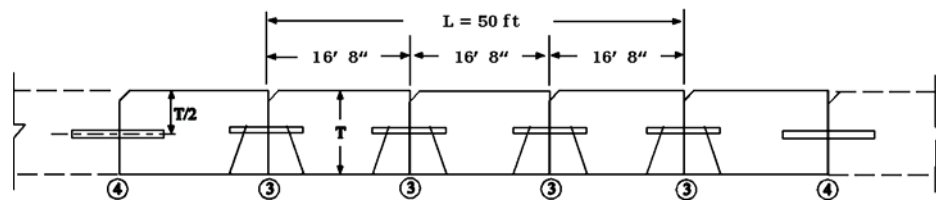

Section C-C

### Section D-D

- 1) Saw at locations 5 and along longitudinal joint (if only one lane is removed) full depth without damage to existing concrete. Saw relief joints as the Engineer directs or approves. Remove the existing JPC pavement to the length and at the locations noted elsewhere in the Contract.  $L = 8$  feet minimum and locations 5 shall not be closer than 8 feet to any transverse joint.
- 2) Install 48 smooth-load transfer dowels, (or 24 if only one lane is removed) 18 inches long (see Standard Drawing No. RPS-020 for size) at locations 5. Install dowels in the existing concrete using epoxy Type IV. Install dowels on 12-inch centers beginning 6 inches from the outside shoulder. Install one-inch expansion joint material in accordance with Standard Drawing No. RPS-020.
- 3) If  $L$  is greater than 20 feet, install new load transfer assembly(s) and construct contraction joints such that the distance between joints in the replaced section is no less than 10 feet nor more than 20 feet.
- 4) If only one lane is removed, install new 3/4-inch tie bars 18 inches long on 30-inch centers in the longitudinal joint using epoxy Type IV. If 2 or more lanes are removed, construct longitudinal joint(s) according to the Standard Drawing except use 3/4-inch tie bars 18 inches long on 30-inch centers.
- 5) Replace with non-reinforced JPC pavement and seal all joints with silicone seals.

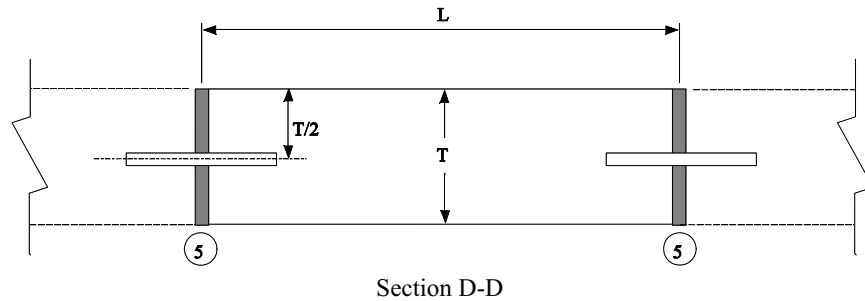



### Section F-F

- 1) Saw at locations 5 full depth without damage to existing concrete. Saw relief joints as the Engineer directs or approves. Remove the existing JPC pavement and dowel assemblies to the length and at the locations noted elsewhere in the Contract.
- 2) Install 48 smooth-load transfer dowels, 18 inches (see Standard Drawing No. RPS-020 for size) at locations 5. Install dowels in the existing concrete using epoxy Type IV. Install dowels on 12-inch centers beginning 6 inches from the outside shoulder. Install one-inch expansion joint material in accordance with Standard Drawing No. RPS-020.
- 3) Install new load transfer assemblies at locations 3.
- 4) Replace with non-reinforced JPC pavement and install a tied longitudinal joint at the location of existing longitudinal joint(s) according to the Standard Drawing, except use 3/4-inch tie bars 18 inches long on 30-inch centers. Construct contraction joints at location 3, and expansion joints at locations 5. Dimension 6 shall be no less than 12 feet nor more than 20 feet. All spaces between joints shall be equal, adjust to provide the minimum number of joints without exceeding the 12-20 foot range. Seal all joints with silicone rubber seals.

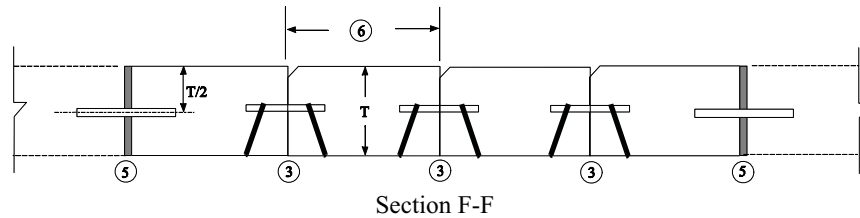

### Section F'-F'

- 1) Saw-cut Line. This one foot is to allow for a form and the removal and replacement shall be incidental to the work, except new asphalt mixture shall be paid direct on a tonnage basis. Recompact the DGA base by mechanical tampers to the Engineer's satisfaction.
- 2) Existing longitudinal joint.
- 3) First slab removal limits and replace 12-foot lane.
- 4) Second slab removal limits and replace 12-foot lane.
- 5) This one foot is to allow for a form on the first pour, and a temporary pavement is required. The Department will not require removal of this one foot if the grade of the existing pavement is adequate to ensure the new concrete can be placed and finished to the satisfaction of the engineer. Note: the above drawing depicts the order of slab removal when both are to be removed at the same location. When only one slab or lane is to be removed, remove and replace according to Section C-C or E-E, as applicable.

Normal half section for removal of one lane concrete patch

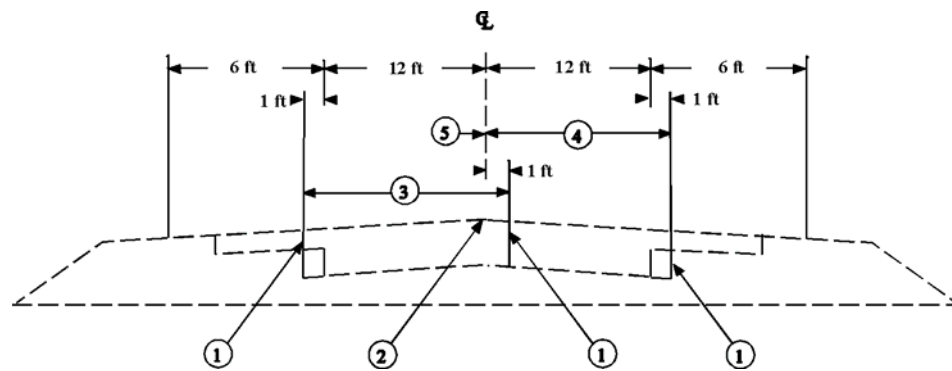

**Section G-G**

- 1) See proposal for location and size of areas to be patched.
- 2) Saw-cut neat straight line pattern around area to be repaired and to a neat vertical face D of 2 inches or deeper. Make all saw cuts approximately parallel to the existing joints.
- 3) Remove, using hand-held equipment, all loose and cracked pavement without disturbing the sound concrete to remain in place.
- 4) Place and cure patch.

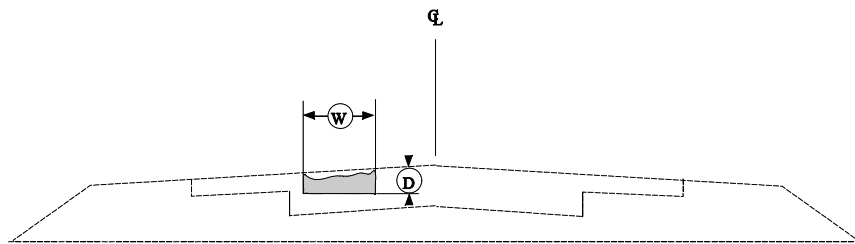

#### 4.0 MEASUREMENT.

**4.1 Remove JPC Pavement.** The Department will measure the quantity in square yards of surface area. The Department will not measure removal of underlying base material for payment and will consider it incidental to Remove JPC Pavement.

**4.2 DGA.** The Department will measure the quantity used to stabilize the existing base or to replace unsuitable material in tons. The Department will not measure removal of existing base material or underlying material for payment and will consider incidental to DGA.

**4.3 Non-Reinforced JPC Pavement.** The Department will measure according to Subsection 501.04.01. The Department will not measure dowels, tie bars, hook bolts, or joint sealing for payment and will consider it incidental to Non-Reinforced JPC Pavement.

**4.4 JPC Pavement 24/48/72.** When listed as a bid item the Department will measure according to 501.04.01. The Department will not measure dowels, tie bars, hook bolts, or joint sealing for payment and will consider it incidental to Non-Reinforced JPC Pavement.

When not listed as a bid item, the Department will measure the quantity as Non-Reinforced JPC Pavement and make no additional payment for its use.

**4.5 Underdrains.** The Department will measure the quantity according to Subsection 704.04. The Department will not measure lateral drains for payment and will consider them incidental to the Underdrains

**4.6 Partial Depth Patching.** The Department will measure the quantity in cubic foot, either from field measurements or the metered quantity from the mixer, as the Engineer determines.

**5.0 PAYMENT.** The Department will make payment for the completed and accepted quantities under the following:

<u>Code</u>	<u>Pay Item</u>	<u>Pay Unit</u>
----	Remove JPC Pavement	Square Yard
00001	DGA	Ton
02069-02071, 02073, 02075, 02084, 02086, 02088	JPC Pavement Non-Reinforced, thickness	See Subsection 501.05
02110	Partial Depth Patching	Cubic Foot
01000	Perforated Pipe, 4-inch	Linear Foot

The Department will consider payment as full compensation for all work required in this provision.

January 1, 2008